

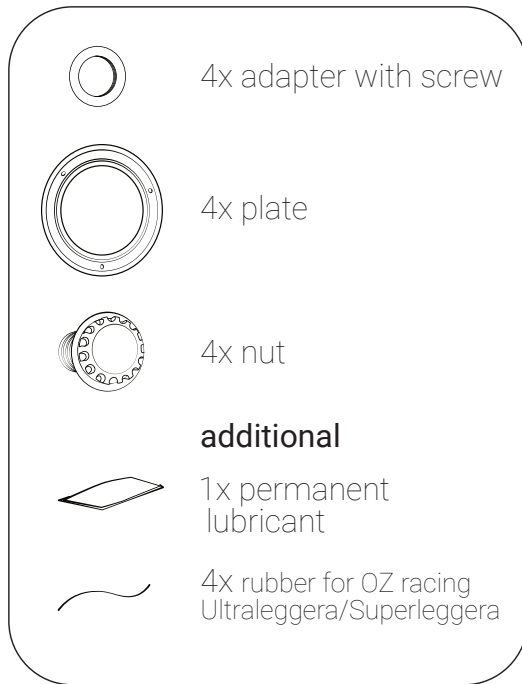

Thank you for your purchase. Inside is a special product for you and your car.

We are pleased to note that we use the latest technology to deliver the highest quality MG-line centerlocks and accessories. Our products have been designed especially for you to fit your style and needs.

≡ New style for your car with *MG Line*



Care about your rims and centerlock. Do not use strong chemical especially soda based.



Not for use on public roads.

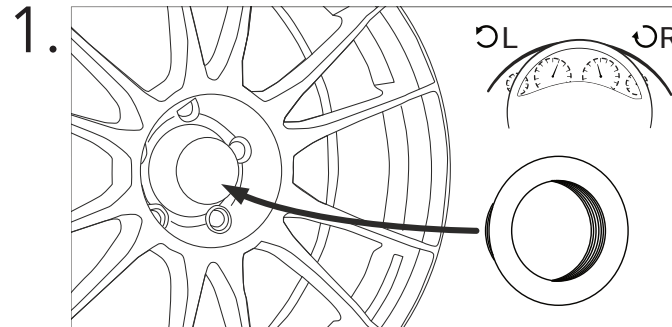

1. Clean before installation. Tighten the adapter into the center hub bore. The left-hand thread is on the driver's side (LHD).

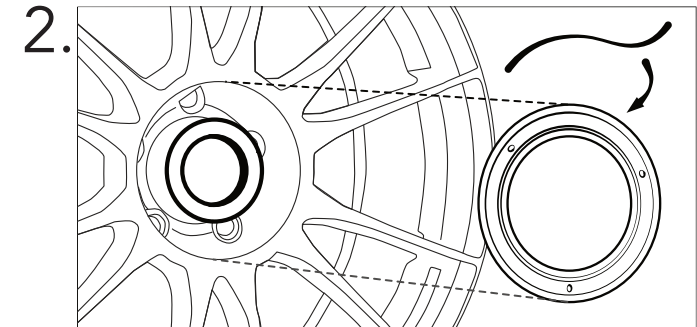

2. To additionally protect the rim, put rubber on the inside of the plate. Put the plate on the rim.

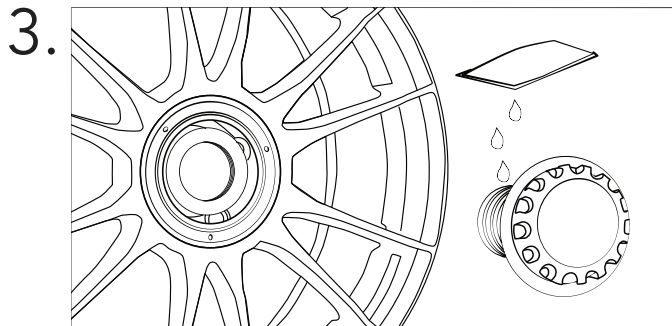

3. Use a little lubricant on the thread. Tighten the central screw. Use strength 10-15 Nm.

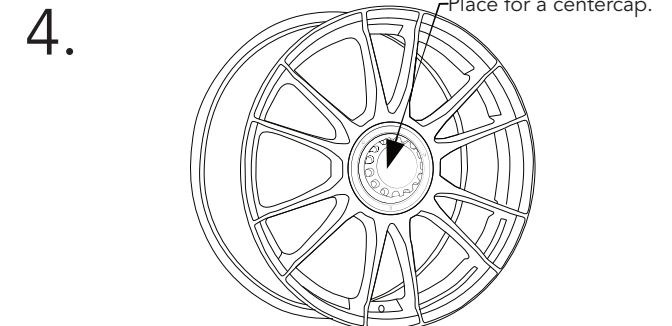

4. You did great, your car is ready to go.

Check our site for video instructions
www.bbscenterlock.com